



KS8-IR8/16/32CIF INFRA-RED ASPIRATED
REFRIGERANT GAS DETECTOR

Installation Manual

Instructions for :-

KS8-IR8/16/32CIF Infra-Red Aspirated Refrigerant Gas Detector

For safe and correct use please read the installation manuals supplied with the equipment.

Contents



Page	
3 - 4	Safety precautions
5	Installation instructions / Overview / Locating the enclosure
6	Choosing end of line positions
7-8	Equipment installation
9-10	Electrical connection / Interface connection
11	I/O PCB connection terminals
12	Sampling tubes / Reference fresh air
13	Sample points / Sample lines
14 -16	Accessories

Safety precautions

Before installation and electric work

Before installing the unit, make sure you read all the "Safety precautions".

Symbols used in the text

-  Warning: Describes precautions that should be observed to prevent danger of injury or death to the user.
-  Caution: Describes precautions that should be observed to prevent damage to the unit.

-  Warning: Carefully read the labels affixed to the main unit.

-  Warning:
 - Ask the dealer or an authorised technician to install the unit.
Improper installation by the user may result in water leakage, electric shock, or fire.
 - Use the specified cables for wiring. Make the connections securely so that any outside forces acting on the cables are not applied to the terminals. Inadequate connection and fastening may generate heat and cause a fire.
 - Never repair the unit. If the controller must be repaired, consult the dealer.
If the unit is repaired improperly, electric shock, or fire may result.
 - When handling this product, always wear protective equipment. EG: Gloves, full arm protection namely boiler suit, and safety glasses.
Improper handling may result in injury.
 - If refrigerant gas leaks during installation work, ventilate the room.
If the refrigerant gas comes into contact with a flame, poisonous gases will be released.
 - Install the controller according to this Installation Manual.
If the unit is installed improperly, electric shock, or fire may result.
Have all electric work done by a licensed electrician according to "Electric Facility Engineering Standard", "Interior Wire Regulations" and the instructions given in this manual and always use a special circuit.
 - If the power source capacity is inadequate or electric work is performed im-properly, electric shock and fire may result.
Keep the electric parts away from any water - washing water etc...
Contact may result in electric shock, fire or smoke.
 - After completing installation work, make sure that refrigerant gas is not leaking.
If the refrigerant gas leaks and is exposed to a fan heater, stove, oven, or other heat source, it may generate noxious gases.
 - Do not reconstruct or change the settings of the protection devices.
If the pressure switch, thermal switch, or other protection device is shorted or operated forcibly, or parts other than those specified by Mitsubishi Electric are used, fire or explosion may result.



To dispose of this product, consult your dealer. Do not use a leak detection additive.

Precautions for devices that use R410A refrigerant

-  Caution:
 - Do not use the existing refrigerant piping.
The old refrigerant and refrigerator oil in the existing piping contains a large amount of chlorine which may cause the refrigerator oil of the new unit to deteriorate. Use refrigerant piping made of C1220 (CU-DHP) phosphorus deoxidized copper as specified in the JIS H3300" Copper and copper alloy seamless pipes and tubes". In addition, be sure that the inner and outer surfaces of the pipes are clean and free of hazardous sulphur, oxides, dust/dirt, shaving particles, oils, moisture, or any other contaminant.
Contaminants on the inside of the refrigerant piping may cause the refrigerant residual oil to deteriorate.
 - Store the piping to be used during installation indoors and keep both ends of the piping sealed until just before brazing.
(Store elbows and other joints in a plastic bag.) If dust, dirt, or water enters the refrigerant cycle, deterioration of the oil and compressor problems may result.
 - Use ester oil, ether oil or alkylbenzene (small amount) as the refrigerator oil to coat flares and flange connections.
The refrigerator oil will degrade if it is mixed with a large amount of mineral oil.
 - Use liquid refrigerant to fill the system.
If gas refrigerant is used to seal the system, the composition of the refrigerant in the cylinder will change and performance may drop.
 - Do not use a refrigerant other than R410A.
If another refrigerant (R22, etc.) is used, the chlorine in the refrigerant may cause the refrigerator oil to deteriorate.
 - Use a vacuum pump with a reverse flow check valve.
The vacuum pump oil may flow back into the refrigerant cycle and cause the refrigerator oil to deteriorate.
Do not use the following tools that are used with conventional refrigerants. (Gauge manifold, charge hose, gas leak detector, reverse flow check valve, refrigerant charge base, vacuum gauge, refrigerant recovery equipment.)
 - If the conventional refrigerant and refrigerator oil are mixed in the R410A, the refrigerant may deteriorate.
If water is mixed in the R410A, the refrigerator oil may deteriorate.
Since R410A does not contain any chlorine, gas leak detectors for conventional refrigerants will not react to it.
 - Do not use a charging cylinder. Using a charging cylinder may cause the refrigerant to deteriorate.
Be especially careful when managing the tools.
 - If dust, dirt, or water gets in the refrigerant cycle, the refrigerant may deteriorate.

Safety precautions

Before installation

-  Caution:
- Do not install the unit where combustible gas may leak.
If the gas leaks and accumulates around the unit, an explosion may result.
-  Caution:
- Ground the unit.
Do not connect the ground wire to gas or water pipes, lightning rods, or telephone ground lines. Improper grounding may result in electric shock.
 - Install the power cable so that tension is not applied to the cable.
Tension may cause the cable to break and generate heat which may, in turn, cause fire.
 - Install a leak circuit breaker, as required.
If a leak circuit breaker is not installed, electric shock may result.
 - Use power line cables of sufficient current carrying capacity and rating.
Cables that are too small may leak, generate heat, and cause a fire.
 - Use only a circuit breaker and fuse of the specified capacity.
A fuse or circuit breaker of a larger capacity or a steel or copper wire may result in a general unit failure or fire.
 - Be very careful regarding product transportation.
Two people should be used to carry products of 20kg or more.
 - Some products use PP bands for packaging. Do not use any PP bands for a means of transportation.
 - Safely dispose of the packing materials.
Packing materials, such as nails and other metal or wooden parts, may cause stabs or other injuries.
Tear apart and throw away plastic packaging bags so that children will not play with them - If children play with a plastic bag which has not been torn apart, they face the risk of suffocation.

Before starting the test run

-  Caution:
- Do not touch the switches with wet fingers.
Touching a switch with wet fingers can cause electric shock.
 - Do not touch the refrigerant pipes during and immediately after operation.
During and immediately after operation, the refrigerant pipes may be hot or cold, depending on the condition of the refrigerant flowing through the refrigerant piping, compressor, and other refrigerant cycle parts. Your hands may suffer burns or frostbite if you touch the refrigerant pipes.
 - Do not operate the air conditioner with the panels and guards removed.
Rotating, hot, or high-voltage parts can cause injuries.
 - Do not turn off the power immediately after stopping operation.
Always wait at least five minutes before turning off the power. Otherwise, water leakage and other problems may occur.

Disclaimer

Warranty:

All products manufactured on behalf of Mitsubishi Electric UK are warranted against defective materials for a period of three years from the date of delivery to the original purchaser.

Warning:

Mitsubishi Electric UK assumes no liability for damages consequent to the user of this product. We reserve the right to change this manual at any time without notice. The information furnished by us is believed to be accurate and reliable. However, no responsibility is assumed by us for its use, nor for any infringements of patents or other rights of third parties resulting from its use.

Installation Instructions

System Overview

The KS8-IR8/16/32C panel is the heart of the refrigerant leak detection system where the air is analysed and the results are displayed. A pump located within the KS8-IR8/16/32C panel sequentially samples air from each of the channels on a continuous basis. Small bore sampling pipe work is installed between the KS8-IR8/16/32C panel and the potential refrigerant leak source to deliver the air for analysis. An inline filter is fitted to each sampling pipe immediately prior to the KS8-IR8/16/32C panel to provide additional protection to the analyser from dirt or grit which may impede the operation of the system. To provide additional sampling locations in close proximity to the potential leak source the sampling pipe work can be split up to 2 ways using manifolds.

Once the installation is complete it is essential the system is commissioned by a suitably qualified technician. Errors or problems with the installation can be identified during the commissioning process. A system which has been incorrectly installed or not commissioned properly may NOT detect leaking refrigerant and hence this process is paramount to the operation and effectiveness of the equipment.

Locating the KS8-IR8/16/32C Enclosure

The main considerations when deciding where to locate the KS8-IR8/16/32C panel are:-

- Locate centrally to minimise sample tube lengths.
- Availability of 230 volt power supply, interface to communication networks and alarm indication equipment.
- Ambient conditions. RH<95%; Temperature range 5 to 50 Deg. C.
- Close to maintenance staff or management for monitoring purposes.
- Easy access for viewing and acknowledging alarms.
- Easy access for service and maintenance.
- Outside of potentially contaminated area.
- Potential damage.
- Operational noise.

Although the sampling tubes can be run up to 100 metres per channel it is advisable to maintain lengths to a minimum to reduce pressure drops and allow sampling times to be minimised.

The KS8-IR8/16C panel requires a Single phase 230 volt, 50Hz, 1 amp power supply, which should be suitably protected and have local isolation.

Maintenance is required periodically so suitable access for technicians to conduct the work without obstructing others should be given consideration.

We advise that the KS8-IR8/16/32C panel should NOT be installed in locations where potential leaks may occur as interrogation of the equipment would only be possible by entering the contaminated area.

The panel should be mounted with the display at eye level for ease of use when viewing data or alarms.

Suitable mechanical protection may be required around the KS8-IR8/16/32C panel to prevent accidental damage if installed in working areas.

The pump inside the KS8-IR8/16/32C panel operates continuously and due to the mechanical noise the panel should not be installed in quiet office areas where it may become a nuisance.

Installation Instructions

Choosing End of Line Positions

The principle considerations when deciding where to monitor for potential leak sources are:-

1. Highest potential for refrigerant leaks.
2. Restricted areas where leaking refrigerant may accumulate.
3. Working areas where leaking refrigerant can potentially exceed health and safety limits.
4. Density of gas being monitored.
5. Air flow around sampling location and possible collection point.

For general monitoring sample points should be at low level below the air conditioning unit approximately 150mm - 250mm above floor level is a good starting point as this would normally keep the filters out of harm.

Restricted spaces and working areas should be monitored if the Health and Safety limits could potentially be exceeded if all the refrigerant in the system escaped into the space.

The exact location of the sampling point is essential once the area to be monitored has been determined, as an incorrectly positioned end of sampling line may cause a delay in sensing a leak or may result in the KS8-IR8/16C/32C panel sucking back liquids.

The density of the gas being monitored is an important factor in choosing positions; HFC refrigerants will fall towards the floor.

Extract fans, condenser fans, fan coil units and ventilation louvres will however, influence the situation and should be considered when selecting the sampling location.

Installation Instructions

Equipment Installation

Locating the KS8-IR8/16C panel

The KS8-IR8/16C panel should be mounted vertically on a flat static surface with the display at eye height. Five of M6 or equivalent fixings should be used to secure the enclosure to the wall. Sufficient free space must surround the analyser to allow the electrical and pneumatic services to be installed together with cooling air and service/maintenance access. Fig 1 indicates a suitable arrangement. The sampling pipe work which connects to the bottom of the KS8-IR8/16C panel may be routed vertically up or down from the analyser so sufficient space should be allowed when deciding on the location. The KS8-IR8/16C panel should be located in a clean dry environment where the ambient conditions do not exceed the recommended limits.

Fig 1.

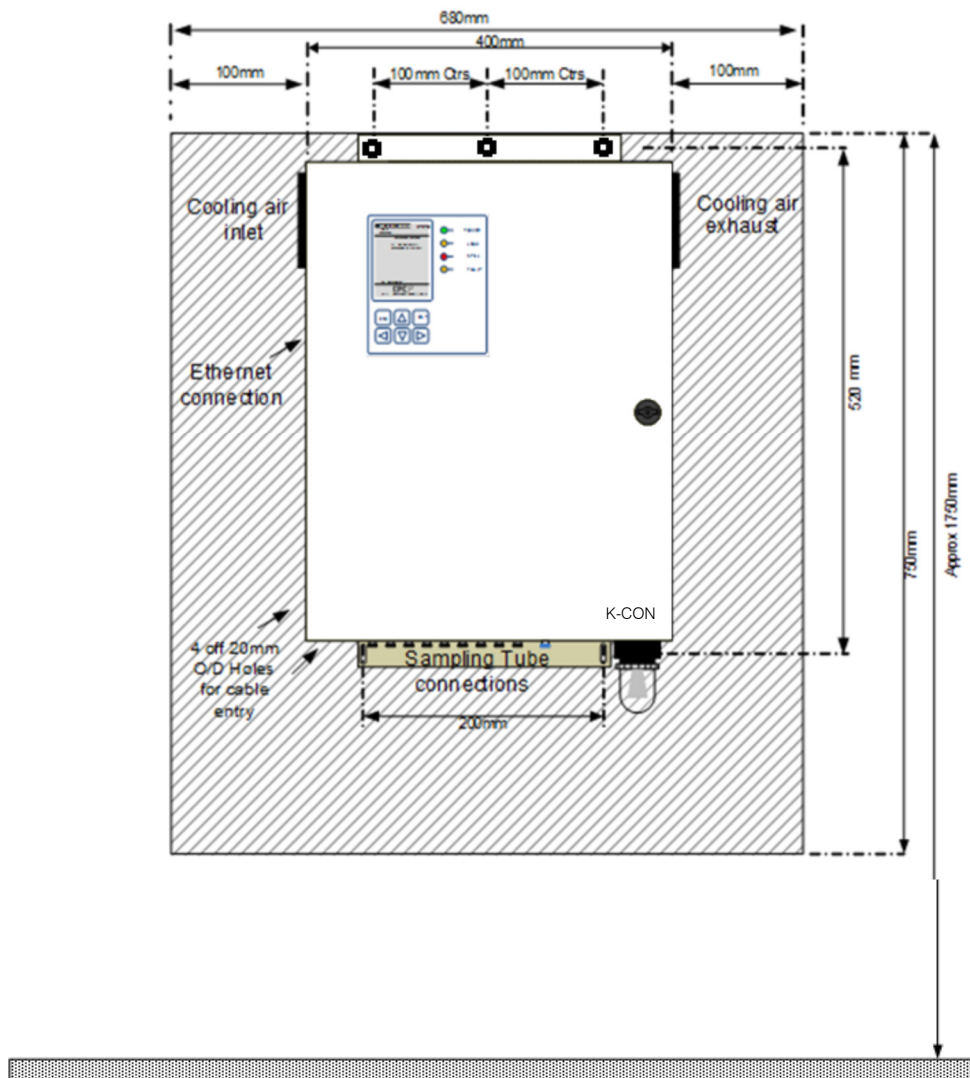

KS8-IR8/16C Installation Arrangement

Installation Instructions

Equipment Installation

Locating the KS8-IR32C panel

The KS8-IR32C panel should be mounted vertically on a flat static surface with the display at eye height. Five of M6 or equivalent fixings should be used to secure the enclosure to the wall. Sufficient free space must surround the analyser to allow the electrical and pneumatic services to be installed together with cooling air and service/maintenance access. Fig 1 indicates a suitable arrangement. The sampling pipe work which connects to the bottom of the KS8-IR32C panel may be routed vertically up or down from the analyser so sufficient space should be allowed when deciding on the location. The KS8-IR32C panel should be located in a clean dry environment where the ambient conditions do not exceed the recommended limits.

Fig 1.

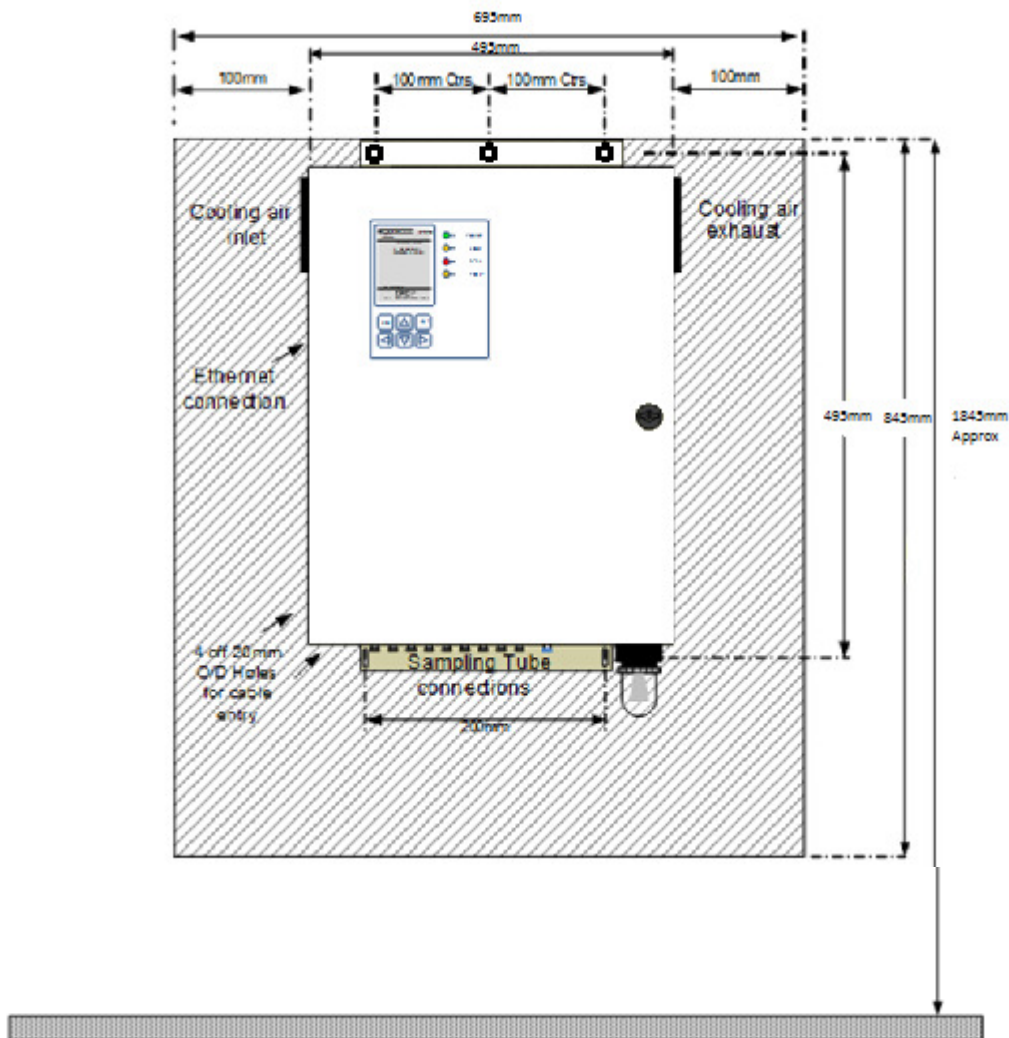

KS8-IR32C Installation Arrangement

Installation Instructions

Electrical Connection

Four of 20mm Cable entry locations are located on the KS8-IR8/16C panel enclosure for power, communications and volt free alarm contacts. An Ethernet socket for connection to a PC or Local Area Network is located on the outside of the enclosure. The cutting of any additional holes into the enclosure will automatically invalidate the manufacturer's warranty. Fig.2 shows the panel wirings.

A 230 volt, 50Hz, single phase power supply rated at 1 amp is required to power the KS8-IR8/16C panel . The supply should be fused or suitably protected. Our preference is an un-switched fused spur located adjacent to the KS8-IR8/16C panel with a suitable method of remote electrical isolation.

Fig 2. KS8-IR8/16C Electrical Panel Wiring

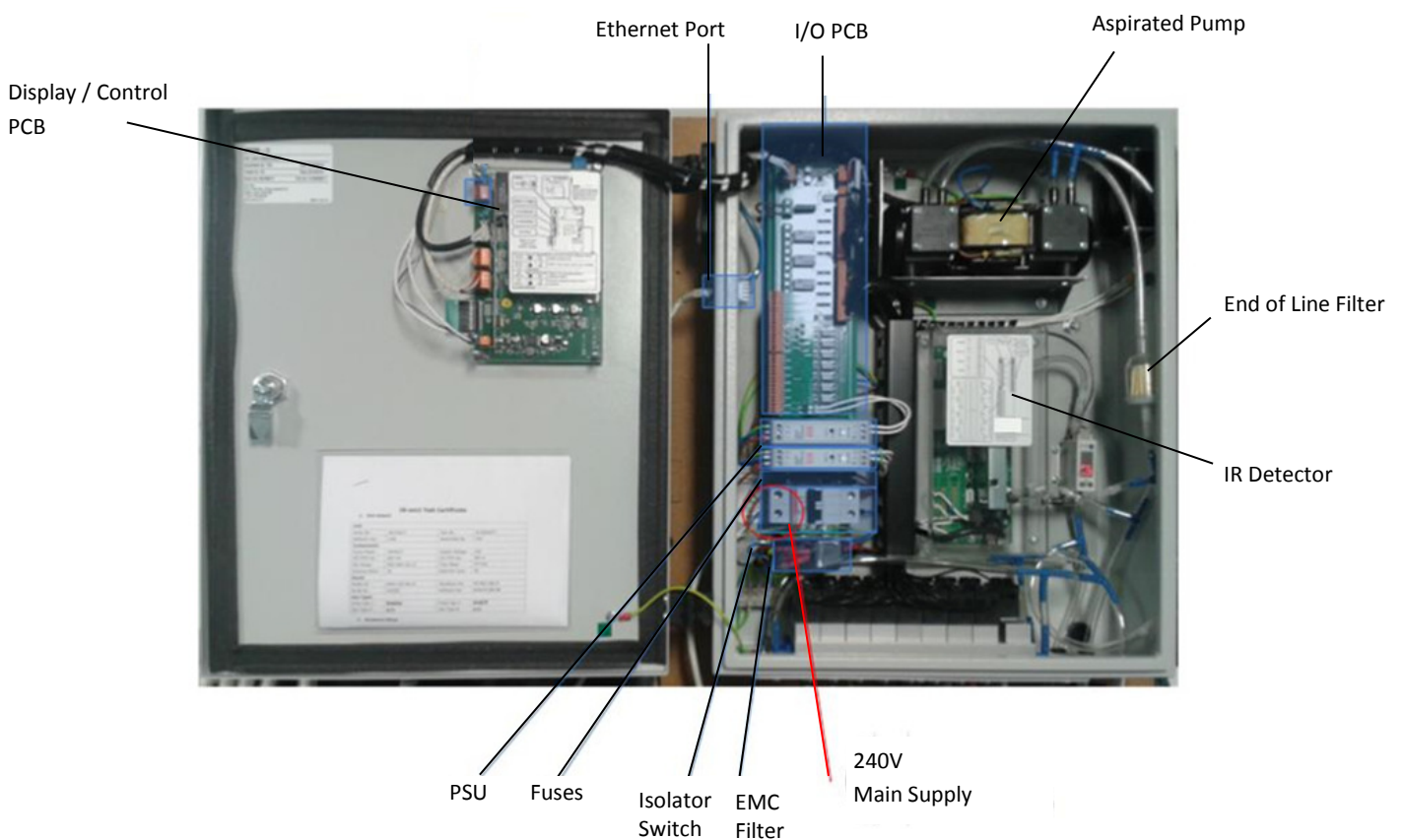

Installation Instructions

Electrical Connection

Four of 20mm Cable entry locations are located on the KS8-IR32C panel enclosure for power, communications and volt free alarm contacts. An Ethernet socket for connection to a PC or Local Area Network is located on the outside of the enclosure. The cutting of any additional holes into the enclosure will automatically invalidate the manufacturer's warranty. Fig.2 shows the panel wirings.

A 230 volt, 50Hz, single phase power supply rated at 1 amp is required to power the KS8-IR32C panel. The supply should be fused or suitably protected. Our preference is an un-switched fused spur located adjacent to the KS8-IR32C panel with a suitable method of remote electrical isolation.

Fig 2. KS8-IR32C Electrical Panel Wiring

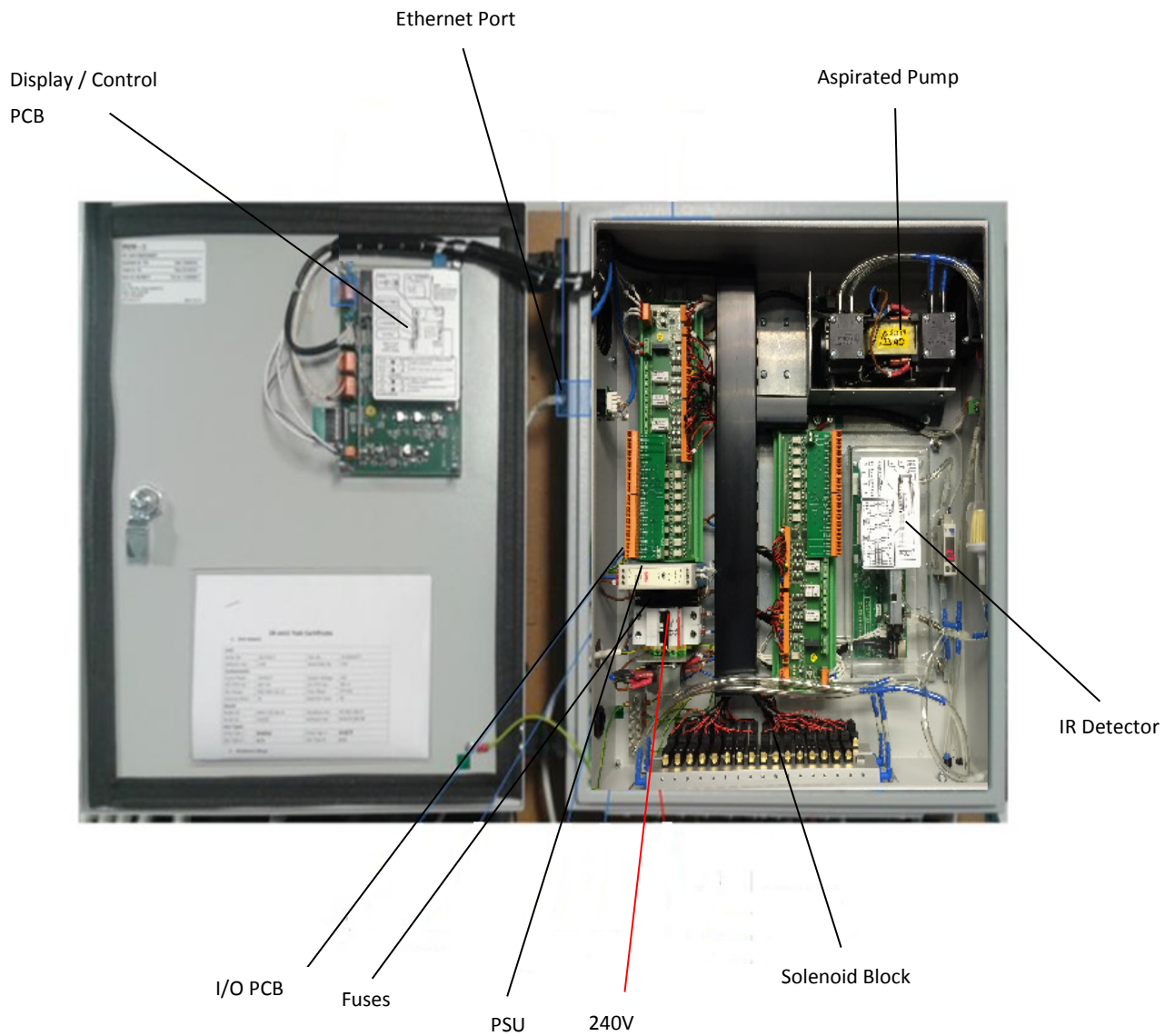

Installation Instructions

I/O PCB Connection Terminals

The unit provides connection terminals for interfacing the unit with external equipment, and connecting to other devices within the unit. All connection terminals (with the exception of the RS485 interface) are located on the I/O PCB. Fig.3 shows the I/O PCB and volt free contacts points.

IMPORTANT: All cabling must enter the unit using the gland holes provided.

Do not drill the enclosure – this will invalidate the unit warranty.

Fig 3 - I/O PCB Connections

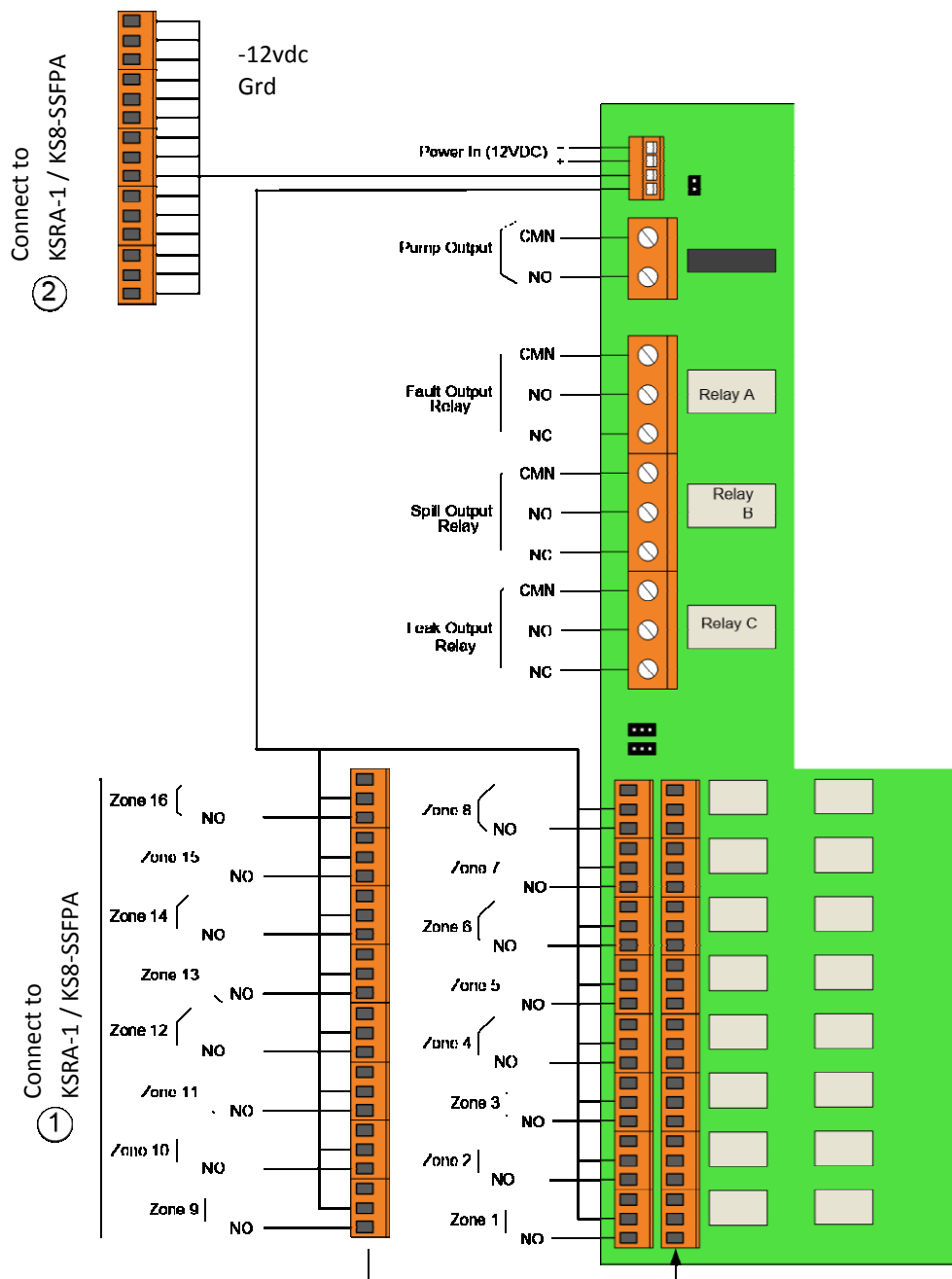

Installation Instructions

Sampling Tube

KS8-BST100	100M Drum - Black	10100218
KS8-BST250	250M Drum - Black	10100219

Black pipe work is provided to deliver the air from the potential leak source to the KS8-IR8/16/32C panel for analysis.

It is essential that the appropriate tool is used to cut the sampling pipe work. This provides a clean and square cut without any burr or swarf being produced. The tubing is 6mm O/D and manufactured from nylon. The recommended maximum sampling tube length from the KS8-IR8/16/32C panel to the sampling location is 100m.

The pipe work should be installed carefully with as long a radius bend as possible to reduce pressure drops. Care must be taken to ensure the tube is not kinked, burnt (from copper pipe brazing) or cut during the installation. The sampling pipe work should be adequately supported on cable tray, ladder rack, basket or inside trunking or conduit and secured as appropriate. The pipe work can be run alongside refrigeration pipe however it should NOT be laid on refrigeration pipe work where the surface temperature may fall below zero. Although insulation is fitted around suction pipes the joints are not always sealed adequately and ice can form which ultimately surrounds the sampling tube.

Note: - Any installation outside should be run in flexible conduct or similar to provide protection from UV degradation.

Reference Fresh Air

During warm up and periodically during normal operation the KS8-IR8/16/32/32C panel requires clean air to set a zero reference point.

An inlet port adjacent to the main sampling channels delivers the clean air when required. The reference clean air should ideally be sourced from outside the building or alternatively from a location where there is no opportunity for the gases being monitored to be sampled. An inline (KS8-IF) and end of line filter (KS8-EF) must be fitted to the clean air reference to protect the KS8-IR8/16/32C panel and the sampling pipe work.

Installation Instructions

Sample Points

The leak detection system works by drawing samples of air into the control panel for analysis. Sample therefore should be taken from areas close to potential leaks or from areas where a build up of gas could occur. For general monitoring sample points should be at low level below the air conditioning unit approximately 150mm - 250mm above floor level is a good starting point as this would normally keep the filters out of harm.

Additional sample points can be added as required and could include branch controller boxes and fan coil units . However these could influence the situation and should be considered when selecting the sampling location.

FIG.1 INSTALLATION EXAMPLE

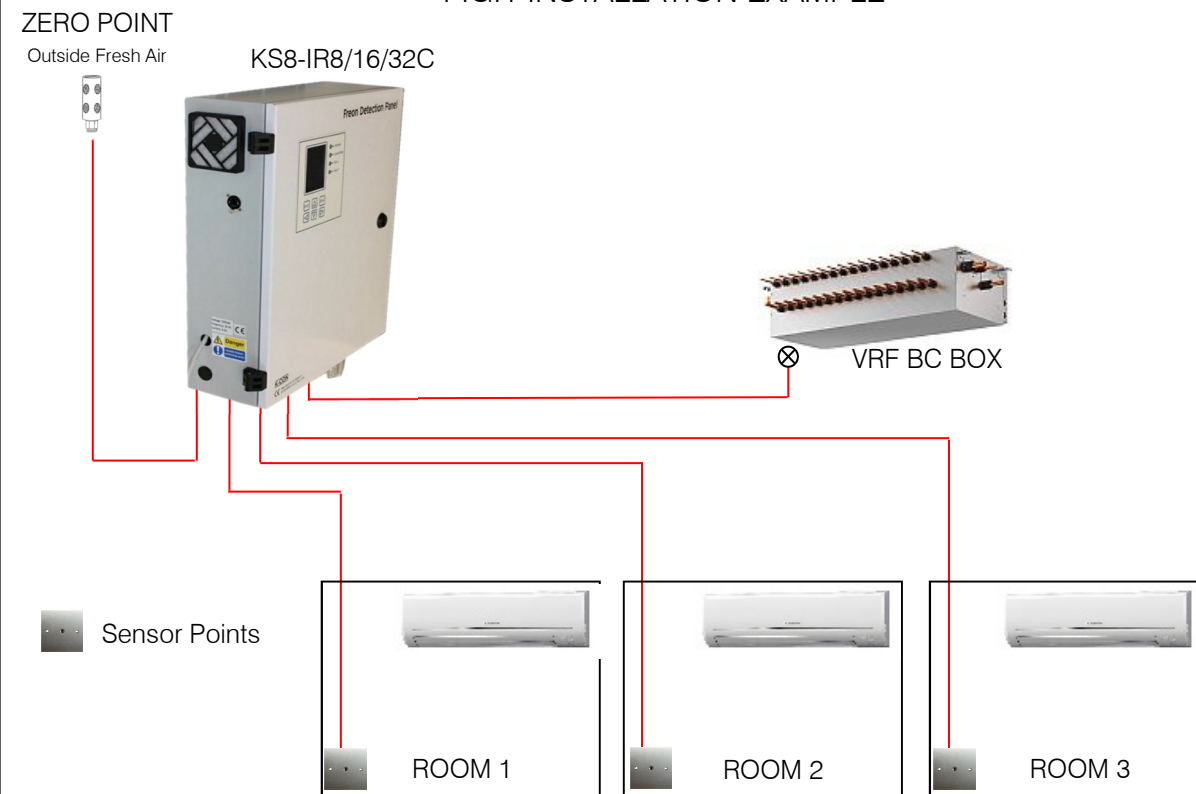

Sample Lines

For general installations 6mm OD, 4mm ID nylon tubing is supplied (KS8-BST100/250). When routing sample lines, be aware that short runs will facilitate faster response times. If possible, sample lines should be run in one continuous length, as using pipe joining couplings will cause flow restrictions. (In practice the cost of a single length of tubing is often less than the coupling.) Avoid tight bends as this will kink nylon tubing causing blocked lines. Sharp corners on framework etc can also cut the sample lines over time, especially on vibrating machinery.

It is best to run pipework at head height or above where it is less likely to encounter mechanical damage, such as being cut or crushed by machinery. Be careful not to cause a hazard to personnel however by suspending pipework across open areas. Also avoid heat sources and hot pipework as this will melt nylon tubing. If a more mechanically resistant tubing is called for, small bore copper tubing can be used in these areas. Tubing should be clipped and tied to framework and walls at regular intervals, similar to cable installations. Avoid unsupported loops and sags that can cause damage to pipework and personnel.

Installation Instructions

Accessories

Sampling Pipe Fittings

All the sampling tube fittings have push fit connections for ease of use. Provided the sampling tube is cut correctly these fittings are very effective. To connect the sampling pipe to a fitting just push the tube into the fitting whilst holding the outside body of the fitting. To remove the sampling pipe work the outer collar requires depressing before pulling the tube. If the tube is pulled before depressing the outer collar the barbs on the fitting may imbed into the tube and make removal more difficult.

Face Plate

Part Number: KS8-SSFP 10100222
 KS8-SSFPA 10100226

KS8-SSFP

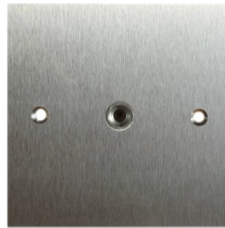
KS8-SSFPA
Complete with Alarm

The KS8-SSFP/A is an aesthetic stainless steel effect flush mounted plate. The sampling tube can be brought into the back of the plate horizontally or vertically.

Mount the face plate as close as practical from the floor or ground (150mm - 250mm), preferably directly beneath the air conditioning unit.

The principle considerations when deciding where to monitor for potential leak sources are:-

1. Highest potential for refrigerant leaks.
2. Restricted areas where leaking refrigerant may accumulate.
3. Working areas where leaking refrigerant can potentially exceed health and safety limits.
4. Density of gas being monitored.
5. Air flow around sampling location and possible collection point.

For general monitoring sample points should be at low level below the air conditioning unit approximately 150mm - 250mm above floor level is a good starting point as this would normally keep the filters out of harm.

Restricted spaces and working areas should be monitored if the Health and Safety limits could potentially be exceeded if all the refrigerant in the system escaped into the space.

The density of the gas being monitored is an important factor in choosing positions; HFC refrigerants will fall towards the floor.

Extract fans, condenser fans, fan coil units and ventilation louvres will however, influence the situation and should be considered when selecting the sampling location.

Installation Instructions

Accessories

Sampling Tube

Part Numbers:	KS8-BST100	100 Metre Black	10100218
	KS8-BST250	250 Metre Black	10100219

Black sampling tube is available in 100M and 250M lengths.

Although the sampling tubes can be run up to 100 metres per channel it is advisable to maintain lengths to a minimum to reduce pressure drops and allow sampling times to be minimised.

Inline Filter

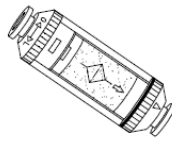

Part Number:	KS8-IF	10100221
--------------	--------	----------

The Inline Filter is fitted with a fine filtration element and is used to prevent the ingress of dust particles, etc. into the KS8-IR8/16C panel which can impair its operation. The inline filters are fitted in series with the main sampling pipe on each channel immediately prior to the inlet port on the KS8-IR8/16/32C panel. The filter element should be replaced when it becomes clogged or dirty. The warranty on the KS8-IR8/16/32C panel will be invalidated if inline filters are not fitted when the unit is in operation.

End of Line Filter (Fresh Air)



Part Number:	KS8-EF	10100223
--------------	--------	----------

The End of Line Filter is fitted at the end of the fresh air sampling pipe work. The filter is slightly coarser than the inline filter and is used to prevent the ingress of debris into the sampling pipe which may result in a blockage. The end of line filter has push fit connections and the procedure for inserting and removing the pipe work is the same as for the inline filters. The filter element should be replaced when it becomes clogged or dirty. End of line filter elements should be adequately supported so water, oil or any other liquids cannot be sucked into the pipe work.

Installation Instructions

Accessories

Two Way Manifold



Part Number: KS8-ST2M 10100225

The 2 Way Manifold is a Y-piece that is used to split the sampling tube for a single channel into 2 ends to provide a local spread of sampling close to the required sampling location (i.e. to enable a single sampling channel to be used to measure two adjacent rooms. To ensure the air is equally sampled from each of the legs it is essential to maintain equal lengths. Excessive sampling pipe on one leg can be neatly coiled and tie wrapped. We recommend that the maximum distance between the manifold and the end of line filter does NOT EXCEED 5 METRES ON EACH LEG.

Straight Connector



Part number: KS8-STSC 10100224

The straight connector is used for joining 6mm O/D tube to 6mm O/D tube. It can be used for joining sampling pipe work to copper tube or simply to replace sections of pipe work if they become damaged. Joints should be avoided whenever possible as they can be a potential source of air ingress into the sampling pipe work.

8/16/32 REMOTE DISPLAY UNIT

Part number KS8-RDU 10100241



The main purpose of the remote display is to list all the KS-8/16/32 IR-CIF units on site, where one or more installed. Ideal location for remote display is reception area where the alarms can be brought to human attention. Remote display can be connected directly to each KS-8/16/32IR-CIF or via IP hub or network. It requires Cat5e cable to make the connection. Maximum six KS-8/16/32IR-CIF panels can be listed. Contact K-con for Separate user manual for RDU remote display, where brief details of functions explained.

Installation Instructions

Please be sure to put the contact address/telephone number
on this manual before handing it to the customer.



mitsubishi electric uk

MITSUBISHI ELECTRIC UK, TRAVELLERS LANE, HATFIELD, HERTFORDSHIRE, AL10 8XB